

Instrument #: 2014-3249
 12/15/2014 10:54:47 AM Total Pages: 1
 ZSC SECTION CORNER CERTIFICATE
 Recording Fee: \$7.00 Transfer Tax: \$0
 Marie Krutzfield, Recorder, Jones County Iowa



PREPARED BY

STEPHEN MICHAEL BRAIN, BRAIN ENGINEERING, INC., 1540 MIDLAND COURT NE, CEDAR RAPIDS, IOWA PH. (319) 294-9424

UNITED STATES PUBLIC LAND SURVEY CORNER CERTIFICATE

LAND SURVEY MONUMENTS SITUATED IN SECTION 19, TOWNSHIP 83 NORTH RANGE 4 WEST OF THE 5TH P.M., JONES COUNTY, IOWA.

NO SCALE

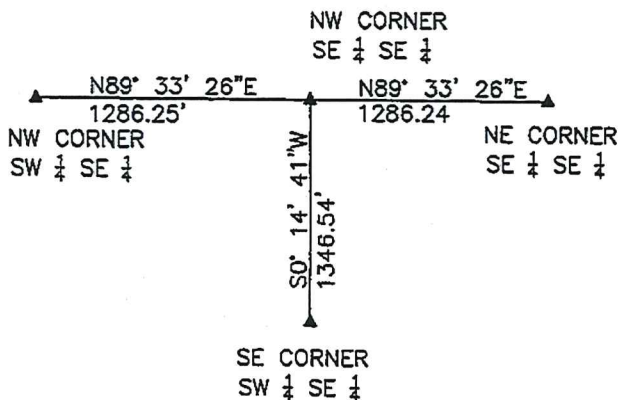
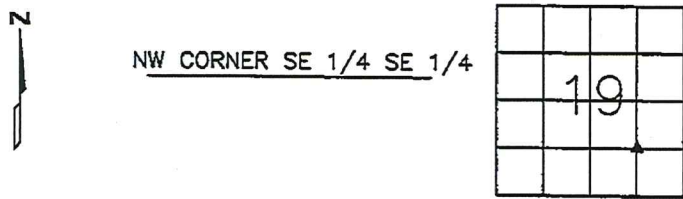

ALL TIES
 1/2" REBAR WITH YELLOW PLASTIC CAP #9647

PREVIOUSLY RECORDED IN BOOK _____ PAGE _____

MONUMENT DESCRIPTION AND HOW ESTABLISHED _____
 SET 1/2" REBAR WITH YELLOW PLASTIC CAP #9647 AT THE INTERSECTION OF THE MIDPOINTS OF THE SE 1/4 OF SECTION 19-83-4.

NO SCALE

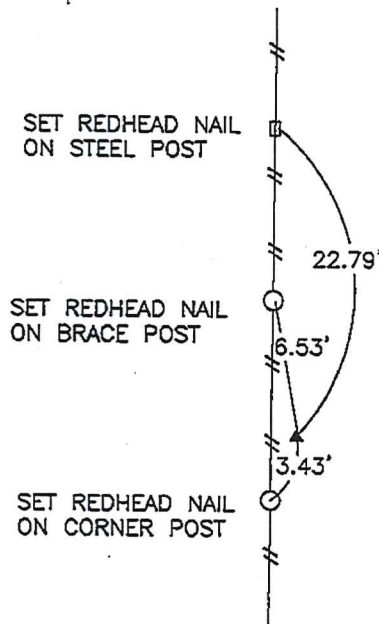
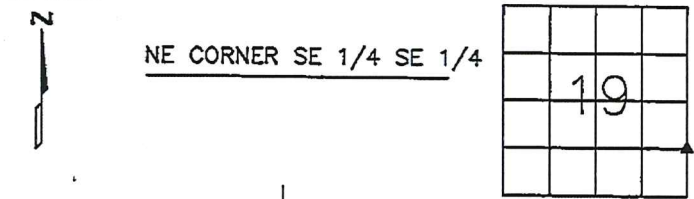

PREVIOUSLY RECORDED IN BOOK _____ PAGE _____

MONUMENT DESCRIPTION AND HOW ESTABLISHED _____
 SET 1/2" REBAR WITH YELLOW PLASTIC CAP #9647 AT THE MIDPOINT ON THE LINE BETWEEN THE E 1/4 CORNER AND THE SE CORNER OF SECTION 19-83-4



I hereby certify that this land surveying document and the related survey work was performed by me or under my direct personal supervision and that I am a duly licensed Land Surveyor under the laws of the State of Iowa.

Signed: *Stephen Michael Brain* Date: 12/12/14
 Stephen Michael Brain, L.S.
 My License Renewal Date is December 31, 2014
 License Number 9647
 Pages or sheets covered by this seal: 1/1

- A.THERE IS NO CERTIFICATE FOR THE CORNER ON FILE WITH THE RECORDER OF THE COUNTY IN WHICH THE CORNER IS LOCATED
- B.THE SURVEYOR IN RESPONSIBLE CHARGE OF THE LAND SURVEYING ACCEPTS A CORNER POSITION WHICH DIFFERS FROM THAT SHOWN IN THE PUBLIC RECORDS OF THE COUNTY IN WHICH THE CORNER IS LOCATED.
- C.THE CORNER MONUMENT IS REPLACED OR MODIFIED IN ANY WAY.
- D.THE REFERENCE TIES REFERRED TO IN AN EXISTING PUBLIC RECORD ARE NOT CORRECT.

CORNERS TO BE INDEXED			
CORNER	SECTION	TOWNSHIP	RANGE
NW CORNER	19	T83N	R4 W
SE 1/4 SE 1/4			
NE CORNER	19	T83N	R4 W
SE 1/4 SE 1/4			

BRAIN ENGINEERING, INC.

1540 MIDLAND COURT NE
 CEDAR RAPIDS, IOWA 52402 284914-70
 (319) 294-9424

PREPARED BY

STEPHEN MICHAEL BRAIN, BRAIN ENGINEERING, INC., 1540 MIDLAND COURT NE, CEDAR RAPIDS, IOWA PH. (319) 294-9424

UNITED STATES PUBLIC LAND SURVEY CORNER CERTIFICATE

LAND SURVEY MONUMENTS SITUATED IN SECTION 19, TOWNSHIP 83 NORTH RANGE 4 WEST OF THE 5TH P.M., JONES COUNTY, IOWA.

NO SCALE



NW CORNER SE 1/4 SE 1/4

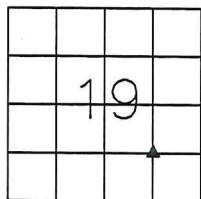

NO SCALE



NE CORNER SE 1/4 SE 1/4

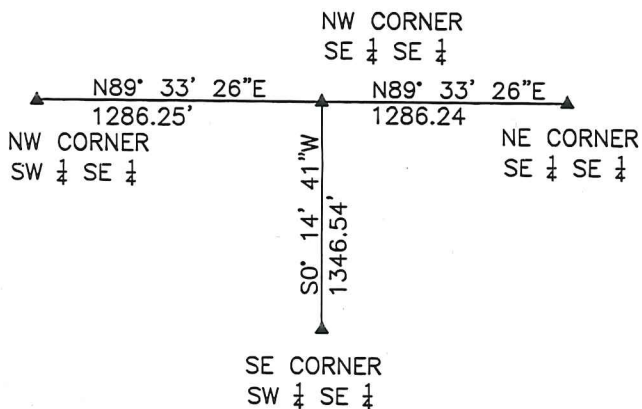
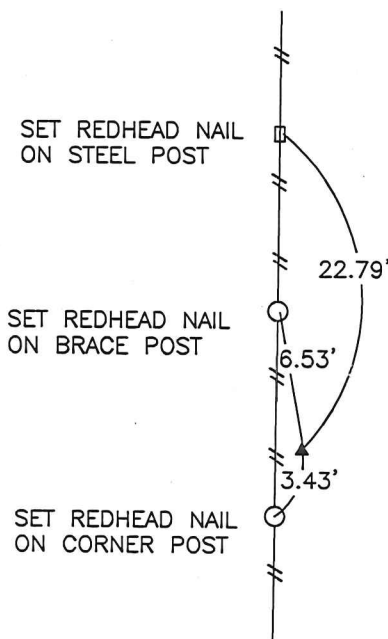
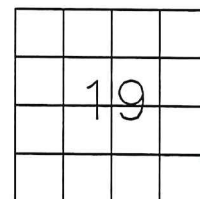

ALL TIES
1/2" REBAR WITH YELLOW
PLASTIC CAP #9647

PREVIOUSLY RECORDED IN BOOK _____ PAGE _____

MONUMENT DESCRIPTION AND HOW ESTABLISHED
SET 1/2" REBAR WITH YELLOW PLASTIC CAP #9647 AT THE INTERSECTION OF THE MIDPOINTS OF THE SE 1/4 OF SECTION 19-83-4.

PREVIOUSLY RECORDED IN BOOK _____ PAGE _____

MONUMENT DESCRIPTION AND HOW ESTABLISHED
SET 1/2" REBAR WITH YELLOW PLASTIC CAP #9647 AT THE MIDPOINT ON THE LINE BETWEEN THE E 1/4 CORNER AND THE SE CORNER OF SECTION 19-83-4



I hereby certify that this land surveying document and the related survey work was performed by me or under my direct personal supervision and that I am a duly licensed Land Surveyor under the laws of the State of Iowa.
Signed _____ Date 12/12/14

Stephen Michael Brain, L.S.
My License Renewal Date Is December 31, 2014
License Number 9647
Pages or sheets covered by this seal: 1/1

- A.THERE IS NO CERTIFICATE FOR THE CORNER ON FILE WITH THE RECORDER OF THE COUNTY IN WHICH THE CORNER IS LOCATED
- B.THE SURVEYOR IN RESPONSIBLE CHARGE OF THE LAND SURVEYING ACCEPTS A CORNER POSITION WHICH DIFFERS FROM THAT SHOWN IN THE PUBLIC RECORDS OF THE COUNTY IN WHICH THE CORNER IS LOCATED.
- C.THE CORNER MONUMENT IS REPLACED OR MODIFIED IN ANY WAY.
- D.THE REFERENCE TIES REFERRED TO IN AN EXISTING PUBLIC RECORD ARE NOT CORRECT.

CORNERS TO BE INDEXED

CORNER	SECTION	TOWNSHIP	RANGE
NW CORNER	19	T83N	R4 W
SE 1/4 SE 1/4	19	T83N	R4 W
NE CORNER	19	T83N	R4 W
SE1/4 SE 1/4	19	T83N	R4 W

BRAIN ENGINEERING, INC.
1540 MIDLAND COURT NE
CEDAR RAPIDS, IOWA 52402
(319) 294-9424

284914-70